

OPTION 1

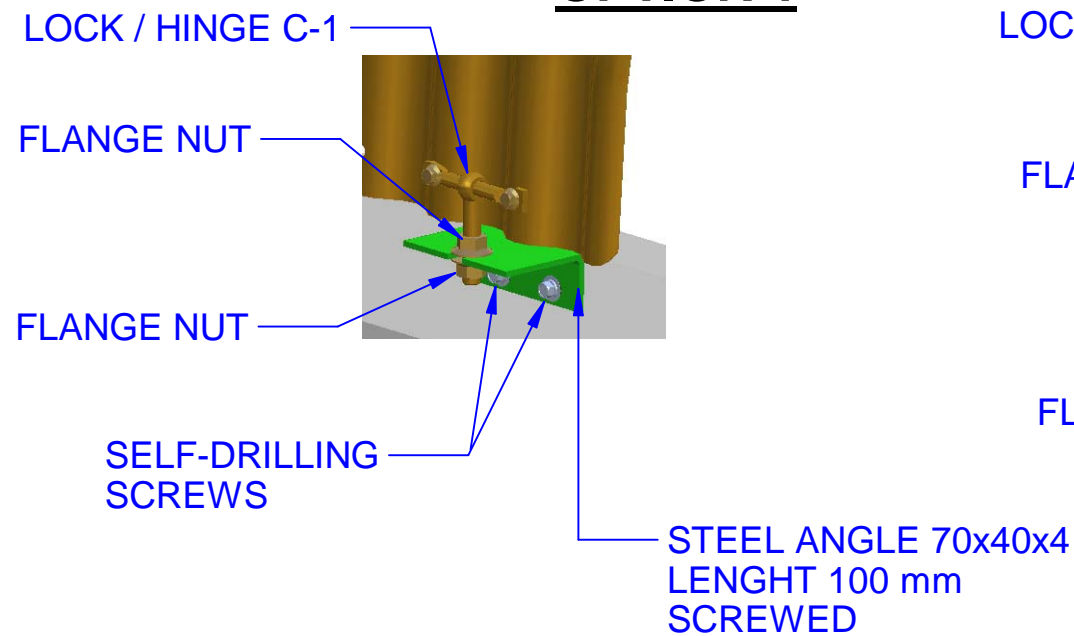

OPTION 2

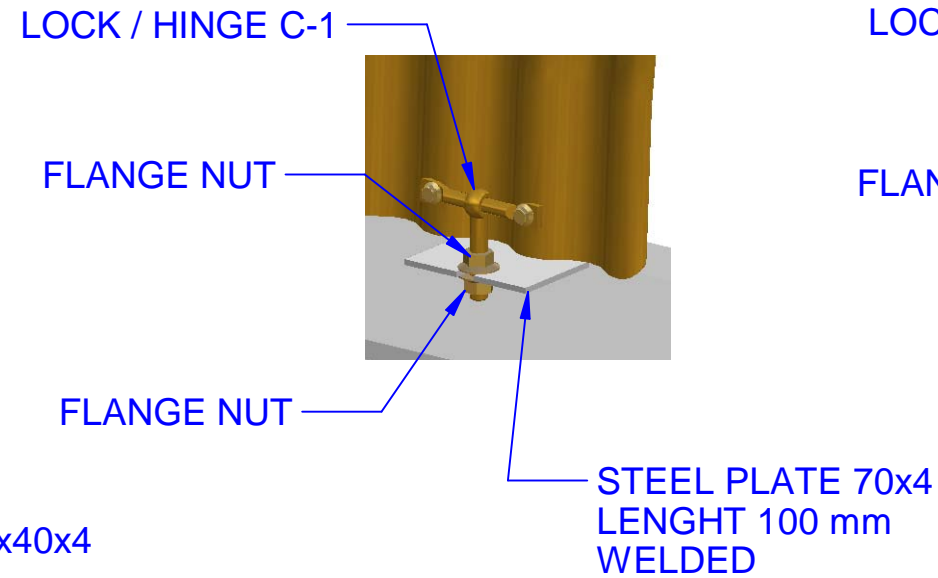

OPTION 3

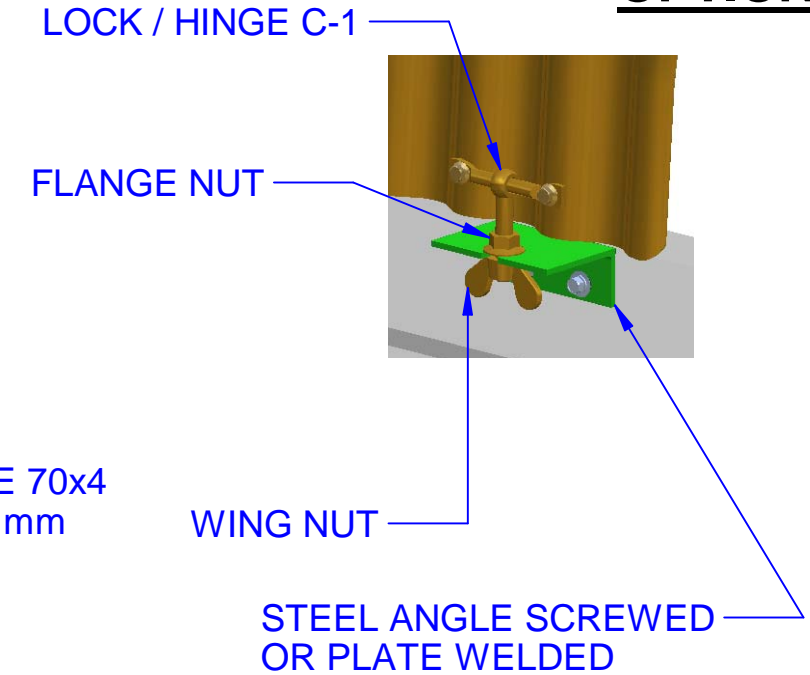

NOT SPECIFIED TOLERANCE

DIMENSIONS		ANGLES	
()	: ±2.00	0°	: ±02' 00"
X.	: ±0.50	0° 0'	: ±00' 30"
X.0	: ±0.25	0° 0' 0"	: ±00' 03"
X.00	: ±0.08		
X.000	: ±0.02		

CAD DRAWING. HANDLING ON CAD SYSTEM ONLY

THIS DRAWING IS OWNED BY CAPOTEX. COPY OR REPRODUCTION IS FORBIDDEN WITHOUT PREVIOUS NOTICE

SCALE	DESIGNED	DRAWN	CHECKED	SHEET 2 OF 4	FORMAT
1:1	M. MATILLA			EUR	A3

MADRID PLUS COVER (GENERAL VIEW)

DRAWING NUMBER
CAPOTAJE MADRID PLUS REV. C.